

Nyloc Insert Nut

Thread Type: UNC / BSW - Coarse

Thread Direction: Right Hand

Material: Stainless Steel

Class Grade: A4-70 G316

Corrosion Protection Level: Ultimate

Standard: NE Series

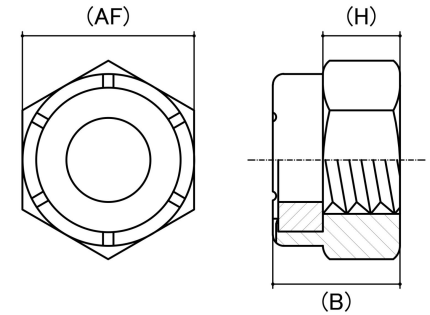

*CAD drawings shown for graphic representation only.**

Size	Thread Pitch (TPI)	Thread Type	Overall Nut Height (B) (mm)		Hex Height (H) (mm)	Across Flats (AF) (mm)		Spanner Size (AF) (inches)	sku (qfind)
			Min	Max	Nom	Min	Max		
#10-24 (3/16")	24	Coarse	5.80	6.30	3.70	9.20	9.53	3/8	41NSC1024M
1/4"	20	Coarse	7.55	8.35	5.72	10.88	11.16	7/16	41NSC14M
5/16"	18	Coarse	8.35	9.10	6.35	12.43	12.76	1/2	41NSC516M
3/8"	16	Coarse	11.10	11.90	8.51	14.00	14.28	9/16	41NSC38M
7/16"	14	Coarse	11.10	11.90	8.23	15.55	15.88	5/8	41NSC716M
1/2"	13	Coarse	14.70	15.45	11.79	18.70	19.05	3/4	41NSC12M
5/8"	11	Coarse	18.67	20.00	15.07	23.42	23.83	15/16	41NSC58M
3/4"	10	Coarse	21.80	22.60	18.90	26.73	27.03	1-1/8	41NSC34M
7/8"	9	Coarse	24.60	25.40	20.07	31.48	31.81	1-5/16	41NSC78M
1"	8	Coarse	25.70	27.40	20.96	36.25	36.58	1-1/2	41NSC1M
1-1/8"	7	Coarse	29.00	30.60	23.63	41.00	41.33	1-11/16	41NSC118M
1-1/4"	7	Coarse	34.50	36.00	28.58	45.75	46.11	1-7/8	41NSC114M

Disclaimer:

Dimensional data and technical information was obtained from publically available sources and not acquired through standard agencies. It has been completed and compiled for reference purposes only; where discrepancies are found they are subject to change without notice. Bolt & Nut Australia makes no warranties or representations regarding the accuracy and validity of the compiled information and data. Contact the relevant standard authorities for accurate and detailed information.

* CAD drawings may not reflect diameter, thread length or overall length.

